

PCT

WORLD INTELLECTUAL PROPERTY ORGANIZATION
International Bureau



INTERNATIONAL APPLICATION PUBLISHED UNDER THE PATENT COOPERATION TREATY (PCT)

BEST AVAILABLE COPY

(51) International Patent Classification 7 : E21B 29/10, 43/10, 17/02, 17/08	A1	(11) International Publication Number: WO 00/26502 (43) International Publication Date: 11 May 2000 (11.05.00)
(21) International Application Number: PCT/GB99/03585 (22) International Filing Date: 29 October 1999 (29.10.99) (30) Priority Data: 09/183,943 31 October 1998 (31.10.98) US (71) Applicant: WEATHERFORD/LAMB, INC. [US/US]; c/o CSC The United States Corporation Co., 1013 Centre Road, Wilmington, DE 19805 (US). (71) Applicant (for GB only): HARDING, Richard, Patrick [GB/GB]; Marks & Clerk, 4220 Nash Court, Oxford Business Park South, Oxford OX4 2RU (GB). (72) Inventors: SMALLEY, Michael; 12410 Raven South, Cyprus, TX 77429 (US). BAILEY, Thomas; 13055 Pebble Brook, Houston, TX 77079 (US). WRIGHT, Ralph; 1 Bailey Hill Close, Kintore, Aberdeen AB51 OXR (GB). HAU- GEN, David; 408 N. Iowa, League City, TX 77573 (US). TILTON, Frederick; 3414 Rolling Terrace, Spring, TX 77373 (US). (74) Agent: HARDING, Richard, Patrick; Marks & Clark, 4220 Nash Court, Oxford Business Park South, Oxford OX4 2RU (GB).	(81) Designated States: AU, CA, GB, NO, European patent (AT, BE, CH, CY, DE, DK, ES, FI, FR, GB, GR, IE, IT, LU, MC, NL, PT, SE). Published With international search report.	

(54) Title: CONNECTOR FOR AN EXPANDABLE TUBING STRING

(57) Abstract

A wellbore tubular patch (2) for patching a hole in a wellbore has been invented, the tubular patch in certain aspects having an expandable top member (6) having a hollow tubular body and a top end and a bottom end, an expandable bottom member (10) having a hollow tubular body and a top end and a bottom end, an expandable outer sleeve (8) in which is secured a portion of the bottom end of the expandable top member, and a portion of the top end of the expandable bottom member inserted into and held within the expandable outer sleeve. A method for making a tubular patch for patching a hole in a tubular in an earth wellbore has been invented, the method in certain aspects including securing a portion of a bottom end of an expandable top member in an expandable outer sleeve, the expandable top member having a hollow tubular body and a top end, and securing a portion of a top end of an expandable bottom member within the expandable outer sleeve, the expandable bottom member having a hollow tubular body.

FOR THE PURPOSES OF INFORMATION ONLY

Codes used to identify States party to the PCT on the front pages of pamphlets publishing international applications under the PCT.

AL	Albania	ES	Spain	LS	Lesotho	SI	Slovenia
AM	Armenia	FJ	Finland	LT	Lithuania	SK	Slovakia
AT	Austria	FR	France	LJ	Luxembourg	SN	Senegal
AU	Australia	GA	Gabon	LV	Latvia	SZ	Swaziland
AZ	Azerbaijan	GB	United Kingdom	MC	Monaco	TD	Chad
BA	Bosnia and Herzegovina	GE	Georgia	MD	Republic of Moldova	TG	Togo
BB	Barbados	GH	Ghana	MG	Madagascar	TJ	Tajikistan
BE	Belgium	GN	Guinea	MK	The former Yugoslav Republic of Macedonia	TM	Turkmenistan
BF	Burkina Faso	GR	Greece	ML	Mali	TR	Turkey
BG	Bulgaria	HU	Hungary	MN	Mongolia	TT	Trinidad and Tobago
BJ	Benin	IE	Ireland	MR	Mauritania	UA	Ukraine
BR	Brazil	IL	Israel	MW	Malawi	UG	Uganda
BY	Belarus	IS	Iceland	MX	Mexico	US	United States of America
CA	Canada	IT	Italy	NE	Niger	UZ	Uzbekistan
CF	Central African Republic	JP	Japan	NL	Netherlands	VN	Viet Nam
CG	Congo	KE	Kenya	NO	Norway	YU	Yugoslavia
CH	Switzerland	KG	Kyrgyzstan	NZ	New Zealand	ZW	Zimbabwe
CI	Côte d'Ivoire	KP	Democratic People's Republic of Korea	PL	Poland		
CM	Cameroon	KR	Republic of Korea	PT	Portugal		
CN	China	KZ	Kazakhstan	RO	Romania		
CU	Cuba	LC	Saint Lucia	RU	Russian Federation		
CZ	Czech Republic	LJ	Liechtenstein	SD	Sudan		
DE	Germany	LK	Sri Lanka	SE	Sweden		
DK	Denmark	LR	Liberia	SG	Singapore		
EE	Estonia						

CONNECTOR FOR AN EXPANDABLE TUBING STRING

This invention is directed to systems for patching a hole or leak in a tubular member in a wellbore; to methods for using such systems; to a tubular patch; and, in one particular aspect, to such a system and methods of its use that can be inserted through a relatively small diameter restriction as is presented by some types of tubing and then into a larger diameter member that has an area to be sealed.

Oil and gas wells are ordinarily completed by first cementing casing in the hole. Occasionally, a leak develops at some point in the casing and permits the loss of well fluids to a low pressure, porous zone behind the casing, or permits an unwanted fluid such as water to enter the well.

It is sometimes necessary to patch a hole or other defect in an oil well pipe such as casing or production tubing by expanding a malleable liner into sealed engagement with the inside wall of the pipe.

A principal use for liners in wells is to avoid the necessity for running an entire string of smaller casing in a well which already has a larger string of casing. Possibly the most common use is in the bottom of the well where the existing casing does not extend to the bottom of the well. In this use, a short liner is lowered through the casing into the bottom of the well where a seal is formed between the liner and casing to provide a metallic liner in the well to substantially its full depth. In such cases a seal between the liner and casing is generally provided by Portland cement pumped in the back of the liner to fill the space between the liner and casing. Such seals are seldom perfect. As a result, if the pressure of fluids from the formations penetrated by the well is applied to the outside of the liner and casing, a leak usually results. The liner may not be as thick or strong as the casing. When pressure is applied outside the liner and casing, the liner is compressed more than the casing and a crack forms between them even if none existed before. As soon as an opening is formed for entrance of fluids between the casing and liner, the pressures inside and outside the casing tend to become balanced, permitting the casing to return to its unstressed condition. This further widens the opening between the casing and the liner. Since the wider the opening, the more the casing stress is relieved and since the more this stress is relieved, the wider the opening

becomes, it is apparent that a leak between the casing and liner can hardly be avoided even though a long overlap of casing and liner is provided.

This problem is particularly acute if it is desired to place a steel liner or patching steel sleeve over parted casing or a split or hole in casing. In this case, it is difficult to place Portland cement between the casing and liner and hold the cement in place until it sets. In addition, the application of pressure outside the liner quickly causes leakage in the manner just described.

Pipe such as casing or tubing for oil wells may have variations in the inside wall which reduce or enlarge the inside diameter of the pipe. If such variations are present in an area of pipe which receives a liner, it is desirable to expand the liner to conform to such variations to provide an effective seal between the liner and the pipe. A difficulty encountered in utilizing liner expanding tools in casing or production tubing is in removing the tool after the tool has been driven through the liner. If there are restrictions in the diameter of the pipe in or above the area covered by the expanded liner, there is more likelihood that the tool may hang up at the restriction and possibly even damage the liner as it is pulled therethrough.

Various devices have been devised for setting liners to patch casing, tubing, or oil well pipe. U.S. Patent 3,191,677 discloses liner setting apparatus with an expander ball which is driven through the liner by an explosive jar. U.S. Patent 3,489,220 discloses a method and apparatus for setting a malleable liner having a reverse bend therein over a hole in the pipe, removing a reverse bend from the liner to enlarge the diameter thereof to slightly less than the inside diameter of the pipe and expanding the liner to fit tightly in the pipe.

U.S. Patent 3,785,193 discloses a tool for expanding a liner to fit tightly against the inside wall of a pipe such as oil well casing or tubing in spite of variations in the inside diameter of the pipe. The tool of this invention includes a mandrel that is adapted to be driven through the liner after the liner has been positioned over the hole or other defect in the pipe. A collet having flexible fingers extending therefrom is mounted on the mandrel and resiliently mounted pins extend from the mandrel to urge the fingers outwardly into yieldable engagement with the liner such that the liner is expanded to conform to the inside wall of a pipe. The collet may be mounted for slidable movement with respect to the laterally extending pins to that the flexible fingers can be moved

inwardly as the tool is lowered into or removed from the pipe thereby preventing the fingers from damaging the liner or otherwise hanging up in the liner or pipe.

One prior art method of repairing leaks in casing includes placing a steel liner in the well, then expanding it against the inside surface of the casing. The liner is corrugated longitudinally to reduce its diameter so that it will pass through the casing easily. A thin coating of an epoxy resin or other cementing material and a glass cloth mat are applied to the outside of the liner before it is run in the well. The corrugated liner is run in the well on a tubing string, then expanded against the casing by drawing an expander device through the liner with the upper end of the liner resting against the lower end of the tubing. The expander device is moved through the liner by a hydraulic pump, operated by fluid supplied through the tubing. This method of placing the liner sometimes presents problems which contribute significantly to the expense of the operation. One problem is that the tubing string must be pulled and run in the well twice, once to attach the sleeve and setting tool and once to remove the setting tool. Another problem is that weak sections in the tubing sometimes fail under the force of the hydraulic pressure used to operate the expander.

U.S. Patent 3,167,122 discloses a method and apparatus for expanding a steel liner in a casing using wire line equipment after the tubing has been removed from the well, thereby reducing the amount of time necessary to place the liner and avoiding the risk of rupturing the tubing with hydraulic pressure. The corrugated liner is supported on a rod attached to the wire line or cable with the rod passing through the longitudinal axis of the liner and the expander device attached to the rod below the liner. An explosive charge inside the liner is detonated when the liner is opposite the leak in the casing to expand the liner against the casing with sufficient force to anchor the liner so that the expander can be pulled through to complete the expansion of the liner.

Many prior art tubular patches are about twenty feet long and comprise two ten foot patch tubulars welded together at the factory with high quality heat-treated welds. To produce a tubular patch longer than this, multiple pieces are often welded together on a rig. Often such welding can present a safety hazard. Also the shipment of relatively longer tubing patches from the factory to a rig site is usually not practical or economical.

There has long been a need for a casing patch system which is efficient and effective, and for a multi-member tubular patch producible at a rig site with no welding or only tack welding. There has long been a need for such a tubular expander patch system which is insertable through a smaller diameter restriction, tubular, or tubular string into a larger diameter tubular, e.g. casing, which has a leak or hole to be repaired.

According to the present invention, there is provided a wellbore tubular patch for patching a hole in a wellbore, the tubular patch having an expandable top member having a hollow tubular body and a top end and a bottom end, an expandable bottom member having a hollow tubular body and a top end and a bottom end, an expandable outer sleeve in which is secured a portion of the bottom end of the expandable top member, and a portion of the top end of the expandable bottom member inserted into and held within the expandable outer sleeve.

Further features of preferred embodiments of the invention are set out in claims 2 to 15.

For a better understanding of the present invention and in order to show how the same may be carried into effect reference will now be made, by way of example, to the accompanying drawings in which:

Figure 1A is a side cross-section view of a patch according to the present invention; Figures. 1B, 1C and 1D show parts of the patch of Figure 1A; Figures 1E, 1F and 1G are end views of the parts of Figs. 1B, 1C, and 1D, respectively; Figure 1H shows a patch before expansion;

Figures. 2A - 2C are top views in cross-section of portions of liner patches according to the present invention;

Figures. 3A - 3C are side cross-section views of a patch system to be used with the present invention; and

Figures. 4A - 4E, 5A, 5B and 6 are enlarged views of parts of the system of Figure 3A.

Figs. 1A - 1G show a tubular patch 2 according to the present invention expanded and installed in a casing 4 in an earth wellbore. Such a patch may be used in both through-tubing and non-through-tubing applications.

The patch 2 has an upper portion 6 to which is secured an outer sleeve 8, e.g. by welding, press fit, gluing, and/or thermal expansion/contraction of the parts. A lower portion 10 received within the outer sleeve 8 has a top end that abuts a bottom end of the upper portion 6. Optionally these ends may be glued together. Alternatively the upper and lower portion ends may be spaced apart from one another within the outer sleeve.

The liner patch is applied to the casing by insertion therein followed by expansion.

Figs. 1B - 1G show parts of the patch 2 in an expanded configuration. Prior to expansion, the patch parts may have a corrugated cross-section. This is shown in Figure 1H, where the corrugated patch portion 6 is shown inside the casing 4 before expansion.

Figs. 2A - 2C show embodiments of cross-section views of the patch parts. A liner patch upper or lower portion 12 shown in Fig. 2A has 8 corrugations each with an angle of about 30° and at an angle of about 75° to each other. A liner patch portion 14 shown in Fig. 2B has 10 corrugations each with an angle of about 39° and at an angle of about 75° to each other. A liner patch upper or lower portion 16 shown in Fig. 2C has 10 corrugations each with an angle of about 20° and at an angle of about 55° to each other. In other aspects, the patch parts may have the cross-section of any suitable known prior art patch members.

The components of the patch 2 (and of any patch or patch part disclosed herein) may be made of metal, steel, stainless steel (including but not limited to 825 incolloy), mild steel (including but not limited to 1011 mild steel), zinc, zinc alloys, aluminium, aluminium alloys, iron, copper, and/or copper alloys. Any or all of the outer surface of the patch 2 may be wrapped in fibreglass.

In one particular aspect, the upper portion 6 is welded to the outer sleeve 8. Such welding may be done at a location remote from a rig. The lower portion 10 is pressed into the outer sleeve 8 without welding and held therein with a friction fit. The press fitting is done at the rig. Thus, a patch is provided at a rig site without the necessity of welding at the rig site. In other embodiments the outer sleeve is welded to the upper portion at the rig site and/or the lower portion is welded to the outer sleeve at the rig site.

The parts of the patch 2 are described as upper portion and lower portion; but it is within the scope of this invention to turn the patch upside down for use; to

interchange the upper and lower portions; and/or to initially secure the outer sleeve to the lower portion.

In certain particular aspects the upper and lower parts of the patch 2 are made of typical wellbore tubulars in ten foot lengths. In one aspect, the upper portion 6 and the lower portion 10 are each about thirty feet long, comprised of three ten foot long tubulars welded and/or screwed together; in another aspect they are forty feet long, made of four such ten foot tubulars. In one aspect, about one to five inches of the upper portion is welded to the sleeve, and in one particular aspect this is about three inches. In one aspect about ten to about thirty inches of the lower portion is fit into the sleeve, and in one particular aspect this is about eighteen inches. In other aspects, including but not limited to in through-tubing applications, the amount of sleeve/lower portion overlap may range between about three feet to about seven feet, and in one particular aspect, this is about five feet. The parts of the patch 2 may have any suitable wall thickness. In one particular aspect, the sleeve has a wall thickness of about .040 inches and is twenty two feet long and the upper and lower portions have a wall thickness of about .125 inches and are about five or about ten feet long.

Fig. 3A shows a system 110 for expanding a liner patch P as described above in a cased wellbore (not shown) prior to movement of the system 110 through the liner patch P.

Fig. 3B shows the system 110 with collet fingers 152 and 192 moved and held outwardly. Fig. 3C shows the cone 111 after it has begun its entry into the liner patch P.

Fig. 4A shows parts of the system 110 for expanding the liner patch of the present invention as shown in Fig. 3A. The system 110 has a cone 111 initially disposed in a sleeve 112 which itself is shear pinned with three shear pins 113 (two shown) to a piston housing 122. The cone 111 has a shaft 114 threadedly engaged in a recess 123 of the piston housing 122. A shoulder 115 of the cone 111 rests initially against a shoulder 116 of the sleeve 112. An upper end 117 of the sleeve 112 is sized, disposed and configured to abut a lower end L of a liner patch P (shown partially in Figs. 3A and 4A) so that a tapered end portion 118 of the cone 111 either initially touches or is closely adjacent the lower end L of the liner patch P. Initially the sleeve 112 prevents the cone 111 from entering the liner patch P.

A lower end 124 of the piston housing 122 is threadedly connected to an upper spring seat 140. An upper piston 120 is movably disposed in an interior piston channel

125 of the piston housing 122. A lower end of a connecting rod 119 is threadedly connected in a top recess 126 of the upper piston 120. A top end (not shown) of the connecting rod 119 is connected to a hollow extension rod (not shown). The connecting rod 119 is movable in the interior piston channel 125 and through an interior channel
5 121 of the cone 111.

In subsequent operations fluid in the interior piston channel 125 is expelled through two relief ports 127 through the piston housing 122. Fluid (e.g. working fluid pumped from the surface by a surface pumping unit through a string interconnected with the connecting rod 119) under pressure (e.g. water, mud, drilling fluid, hydraulic
10 fluid) flows through the string (e.g. tubular string, coiled tubing string, etc). through an interior channel 128 of the connecting rod 119, out through two ports 129 and into a sealed space below the upper piston 120 in the interior piston channel 125.

An O-ring seal 130 seals the connecting-rod-119-piston-housing-122 interface. A T-seal 131 (made e.g. of elastomeric or rubber material, e.g. commercially available
15 Viton material) seals the upper-piston-120-piston-housing-122 interface. A T-seal 132 seals the upper-spring-seat-140-connecting-rod-134 interface. An O-ring seal 133 seals the piston-housing-122-upper spring seat 140 interface.

The upper piston rod 134 moves within an interior channel 141 of the upper spring seat 140; within a set of belleville springs 151 positioned in an upper collet 150;
20 within a spring sleeve 153 in the upper collet 150; within a coil spring 154; and within a collet expander 170 (see Figs. 4A, 4B, and 4C).

A lower end 142 of the spring seat 140 is threadedly connected to an upper end of the upper collet 150. The belleville springs 151 are disposed in an interior channel 155 of the upper collet 150 with a top end of the springs 151 abutting the lower surface
25 of the upper spring seal 140. Fluid relief ports 156 provide for the expulsion of fluid from within the interior channel 155.

The lower end of the belleville springs 151 abut a top surface of a flange 158 of the spring sleeve 153. A top end of the coil spring 154 abuts a lower surface of the flange 158 and a bottom end of the coil spring 154 abuts a top end 171 of the collet
30 expander 170. A series of expandable fingers 152 are formed around the lower end of the upper collet 150, each with a lower recess 157 and with stress relief holes 159 therebetween (see Fig. 4E). Also each finger 152 has a male detent 160 initially receivable and holdable in a corresponding female recess 172 of the collet expander.

170. In one particular embodiment the fingers 152 are about fourteen inches long with a space of about one-eighth inch between adjacent fingers and as shown as shown in Fig. 3E with ends of fingers 152 offset from ends of fingers 192. About three thousand pounds of force is required to move such fingers out of their corresponding female recesses. In such an embodiment the belleville springs 151 have a spring force between
5 about one thousand four hundred to about seven thousand pounds and, in one particular aspect, about four thousand pounds; and the coil spring 154 has a spring force between about seven hundred pounds to about two thousand five hundred pounds and, in one particular aspect, about one thousand five hundred pounds. In such an embodiment a
10 force of about seven hundred and fifty pounds must be continuously applied to move the collet fingers along the outer edge of the collet expander 170 and a force of about four thousand pounds is needed to move the male detents 160 out from the corresponding female recesses 172. Bottoming out (e.g. lower end abuts top of collet expander) of the spring sleeve 153 isolates the coil spring 154 and permits a load to be
15 transmitted to the belleville springs 151 so that sufficient force can be applied to move the fingers along the collet expander.

The collet expander 171 is generally cylindrical with a top inner channel 173 in the top end 171 in which the upper piston rod 134 moves and with a central channel 174 in which the upper piston rod 134 moves and in which moves a lower piston 180 to
20 which a lower end of the upper piston rod 134 is threadedly connected. Each male detent 160 of the fingers 152 is movable into a female recess 175 on the collet expander 170. Fluid relief ports 176 provide for the expulsion of fluid from within the collet expander 170.

Working fluid from the surface is flowable down through the upper piston rod
25 134 and out through ports 181 in the lower piston 180 into a space in the central channel 174 between the lower piston 180 and a top end of a lower collet expander body 177 (with some space between the lower piston 180 and the interior surface of the central channel 174). These structures are sealed similarly to those related to the upper spring seat.

30 Fingers 192 of the lower collet 190 have male detents 199 which are initially held in corresponding female recesses 178 of the lower collet expander body 177. Top curved surfaces 191 of the fingers 192 correspond to the recesses 157 of the fingers 152 and are receivable therein.

The upper and lower ends of the collet expander 170 and its central portion are sized and configured to provide a desired amount of radial expansion of the fingers 152 and 192 which completely encircle the collet expander. In certain preferred embodiments (e.g. the specific embodiment above in which belleville springs have a spring force of about four thousand pounds) the initial maximum diameter of the system 110 (e.g. the diameter at the initial location of the fingers 152 or 192 in Fig. 4A) is slightly less than 4.4. inches and the expanded diameter (with the fingers 152, 192 having moved so their male detents are in the female recesses 175 and 179, respectively) is slightly less than 5.921 inches. In other embodiments expansion is about one, one and a half, two, three, six, twelve, twenty or thirty inches.

A lower piston rod 194 has a top end threadedly connected to the lower piston 180 and a bottom end threadedly connected to a bull plug 230. The lower piston rod 194 movably extends through the lower collet expander body 177; through a coil spring 195 in the lower collet 190; through a spring sleeve 196 within the coil spring 195; through a set of belleville springs 197; and through a lower spring seat 220. The coil spring 195, like the previously described coil spring 154, may be like the specific embodiments of the coil spring 154 described above. The belleville springs 197 are like the described belleville springs 151; and certain specific embodiments thereof are like embodiments of the belleville springs 151 described above.

Fluid relief ports 198 provide for the expulsion of fluid from within the lower collet 190. An inner shoulder 205 of the lower collet 190 is movable to abut the lower end of the lower collet expander body 177 thereby arresting motion of the lower collet with respect to the collet expander 170. The fingers 192 are formed and configured as the fingers 152, described above, the holes 201 therebetween.

Figs. 5A and 5B show relative positions of certain parts of the system 110 upon the application of working fluid under pressure. The force of the fluid has moved the upper piston housing 122 down with respect to the upper piston 120 and has moved the collet expander 170 down with respect to the lower piston 180 by applying sufficient force to move the fingers' male detents from the recesses 172, 178 respectively, along the exterior of the collet expander 170, and into the recesses 175, 179 respectively. The top curved finger portions 191 of the fingers 192 have moved into the recesses 157 of the fingers 152. The shear pins 113 have not yet been sheared and the cone 111 has not

yet moved into the liner patch P. As the pistons are moving in the collet expander, the pistons of the setting tool are moving.

As shown in Fig. 6, an upward pull on the system 110 from the setting tool has sheared the shear pins 113 releasing the cone 111 and housing 122; and the cone 111
5 has commenced its entry into the liner patch P forcing it apart within the casing (not shown). As described above, the cone 111 has been prevented from entering the liner patch P until the collet fingers 152 and 192 have fully expanded over the collet expander 170. If the cone 111 were permitted to prematurely enter the liner patch P without full extension of the fingers 152, 192 the cone along and/or the improperly
10 expanded fingers may not adequately expand the liner patch P to achieve a good seal of a leak area.

The length of the extension rod 134 is related to the length of the liner patch P used. The length of the liner patch P also determines the length of additional rods (extension rods) connected to the setting tool. By using overlapping fingers 152 and
15 192 (see Fig. 4E) and with the top curved portions 191 resting in the corresponding recesses 157, no gap between finger ends of fingers 152 and 192 is presented to the liner patch P, pressure distribution from the fingers to the patch is uniform, and the patch is substantially all "ironed out" by the collet fingers.

The major components of the system 110 may be made of steel, e.g. 4140 steel.
20 The polish rods may be made of 17-4PH stainless steel and the upper and lower collets may be made of 4145 steel. In other aspects the components are made of brass, bronze, aluminium, zinc, other suitable metals, or alloys or combinations thereof.

Once the collet expander and fingers have been pulled through the liner patch P, the circulation of working fluid is stopped, and the system is raised by pulling up on the
25 working string. The hold down anchor apparatus is automatically released when fluid under pressure ceases to be pumped to the hold down anchor apparatus. The system is then raised a desired amount and the hold down is re-set, working fluid is again circulated re-expanding the collet fingers, and the system 110 is again pulled further up through the liner patch P. This is done until the liner patch P has been expanded along
30 its entire length. Once the system 110 is removed from the liner patch P, the anchoring hold down and the collets automatically contract so that the system 110 assumes its original diameter and is freed for removal from the wellbore. In a system with a collet fingers about fourteen inches long as described above, about two feet of a liner patch P

are expanded for an initial stroke of a setting tool. Each subsequent stroke expands about ten feet of the liner patch P.

In a typical operation of a system 110 to patch a casing in a wellbore, the system is run into a cased wellbore and may be run through an interior string, e.g. a tubing string, with a smaller inner diameter than that of casing which extends down below a lower end of the inner tubing string. Once the system exits the tubing string, it is moved to a location in the casing at which there is a hole or leak are to be patched. With the system properly located, working fluids are circulated down to the system at about 1000 p.s.i. to expand the collet fingers. Working fluid pressure is then increased to shear the cone shear pins, e.g. to about 1500 p.s.i. Then pressure is increased e.g. to 3500 p.s.i. to 5000 p.s.i. to pull the collet through the patch as the setting tool pulls the expanded collet assembly through the liner patch. Working fluid circulation is then stopped and the system is then pulled up on to re-set the setting tool to re-stroke hydraulic cylinders in the setting tool. Then the expansion cycle is repeated until complete liner patch expansion is achieved. A known stroke indicator, for example that shown in WO 98/21444, may be used to indicate the end of the expansion cycle.

CLAIMS:

1. A wellbore tubular patch (2) for patching a hole in a wellbore, the tubular patch comprising
an expandable top member (4) having a hollow tubular body and a top end and a
5 bottom end,
an expandable bottom member (10) having a hollow tubular body and a top end
and a bottom end,
an expandable outer sleeve (8) in which is secured a portion of the bottom end of
the expandable top member, and
10 a portion of the top end of the expandable bottom member inserted into and held
within said expandable outer sleeve.
2. A tubular patch as claimed in claim 1, wherein the expandable top member (4),
the expandable bottom member (10) and the expandable outer sleeve (8) are corrugated
15 in cross-section prior to expansion.
3. A tubular patch as claimed in claim 1 or 2, wherein the expandable top member
and the expandable outer sleeve are held together by welding, and the expandable outer
sleeve and expandable bottom member are held together by friction fit.
20
4. A tubular patch as claimed in claim 3, wherein the expandable top member and
expandable outer sleeve are welded together at a site remote from a rig and the
expandable bottom member and expandable outer sleeve are press fit together at the rig.
- 25 5. A tubular patch repair system for closing off a hole in a select tubular of a
tubular string in a wellbore, the wellbore extending from an earth surface to a point
down therefrom, the tubular string including a first part having a first inner diameter and
a second part having a second inner diameter, the second inner diameter greater than the
first inner diameter, the select tubular in the second part of the tubular string, the tubular
30 patch repair system including a tubular patch (2) with an expandable top member (4)
having a hollow tubular body and a top end and a bottom end, an expandable bottom
member (10) having a hollow tubular body and a top end and a bottom end, an
expandable outer sleeve (8) in which is secured a portion of the bottom end of the

expandable top member, and a portion of the top end of the expandable bottom member inserted into and held within the expandable outer sleeve and the tubular patch initially sized for movement through the first part of the tubular string and enlargeable upon movement into the second part of the tubular string.

5

6. A method for patching a hole in a tubular in a wellbore, the method comprising introducing a tubular patch system into a tubular string in a wellbore and locating it adjacent a hole in the tubular, the tubular patch system including a tubular patch (2), an expandable top member (4) having a hollow tubular body and a top end and a bottom end, an expandable bottom member (10) having a hollow tubular body and a top end and a bottom end, an expandable outer sleeve (8) in which is secured a portion of the bottom end of the expandable top member, and a portion of the top end of the expandable bottom member inserted into and held within the expandable outer sleeve, and

10

15

expanding the tubular patch to close off the hole in the tubular.

7. A method as claimed in claim 6, wherein the expandable top member and the expandable outer sleeve and expandable bottom member are held together by friction fit.

20

8. A method for closing off a hole in a select tubular in a second part of a tubular string, the tubular string in a wellbore, the wellbore extending from an earth surface to a point down therefrom, the tubular string including a first part having a first inner diameter and a second part having a second inner diameter, the second inner diameter greater than the first inner diameter, the method comprising

25

introducing a tubular patch repair system into and through the first part of the tubular string, the select tubular, the tubular patch repair system for closing off the hole in the select tubular, the tubular patch repair system comprising an expandable top member (4) having a hollow tubular body and a top end and a bottom end, an expandable bottom member (10) having a hollow tubular body and a top end and a bottom end, an expandable outer sleeve (8) in which is secured a portion of the bottom end of the expandable top member and a portion of the top end of the expandable bottom member inserted into and held within the expandable outer sleeve, wherein the

30

expandable top member and the expandable outer sleeve are held together by welding; and the expandable outer sleeve and expandable bottom member are held together by friction fit,

5 moving the tubular patch repair system into the second part of the tubular string,

enlarging the tubular patch repair system within the second part of the tubular string for repair operation therein, and

activating the tubular patch repair system to close off the hole in the select tubular.

10

9. A method for making a tubular patch for patching a hole in a tubular in an earth wellbore, the method comprising

15 securing a portion of a bottom end of an expandable top member (4) in an expandable outer sleeve (8), the expandable top member having a hollow tubular body and a top end, and

securing a portion of a top end of an expandable bottom member (10) within the expandable outer sleeve, the expandable bottom member having a hollow tubular body.

20 10. A method as claimed in claim 9, wherein the portion of the bottom end of the expandable top member is secured in the expandable outer sleeve by welding.

25 11. A method as claimed in claim 9 or 10, wherein the portion of the top end of the expandable bottom member is held within the expandable outer sleeve with a friction fit.

12. A method as claimed in claim 9, 10 or 11, wherein the portion of the bottom end of the expandable top member is secured in the expandable outer sleeve by welding at a site remote from a rig.

30

13. A method as claimed in any of claims 9-12, wherein the portion of the top end of the expandable bottom member is held within the expandable outer sleeve with a friction fit at the rig.

14. A method as claimed in any of claims 9-13, wherein the expandable top member, the expandable bottom member, and the expandable outer sleeve are corrugated in cross-section prior to expansion.
- 5 15. A method for making a tubular patch for patching a hole in a tubular in an earth wellbore, the method comprising
- securing a portion of a bottom end of an expandable top member (4) in an expandable outer sleeve (8), the expandable top member having a hollow tubular body and a top end, and
 - 10 securing a portion of a top end of an expandable bottom member (10) within the expandable outer sleeve, the expandable bottom member having a hollow tubular body.

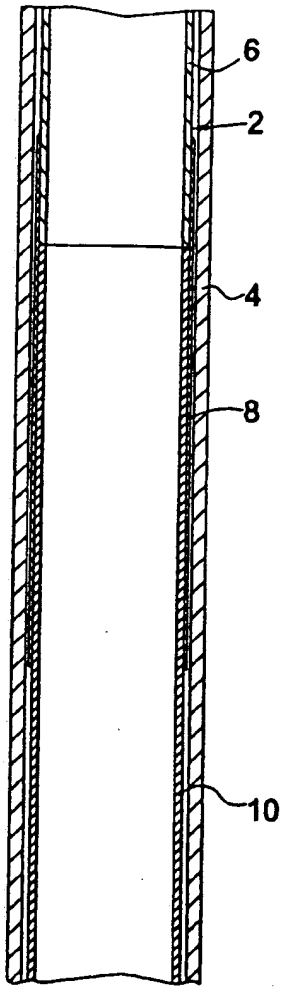

Fig. 1A

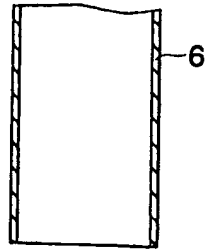

Fig. 1B

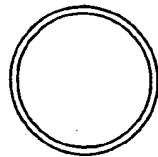

Fig. 1E

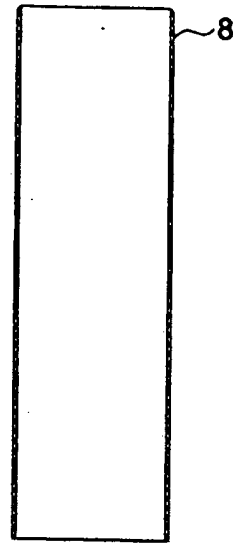

Fig. 1C

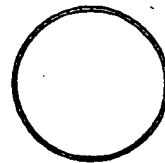

Fig. 1F

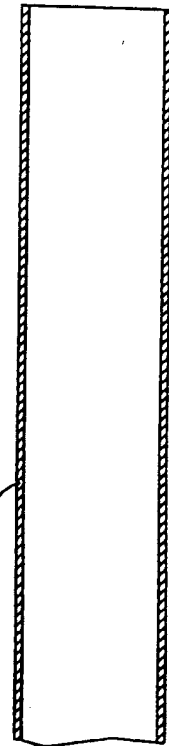

Fig. 1F

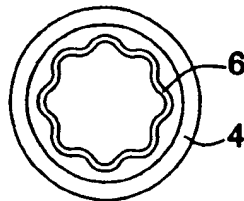

Fig. 1H

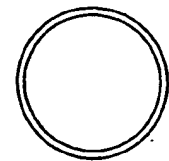

Fig. 1G

2/6

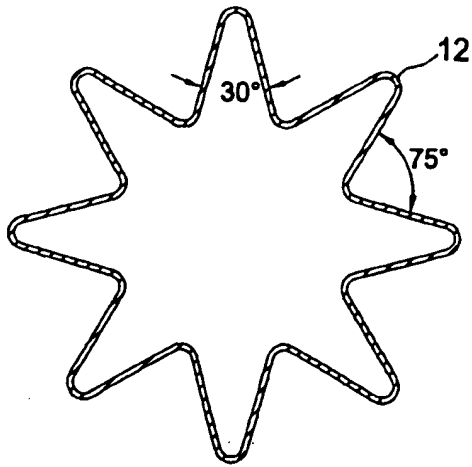

Fig.2A

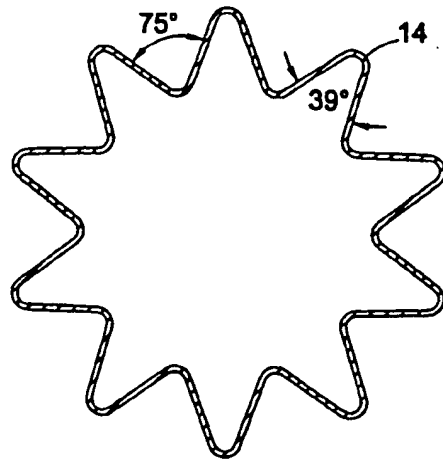

Fig.2B

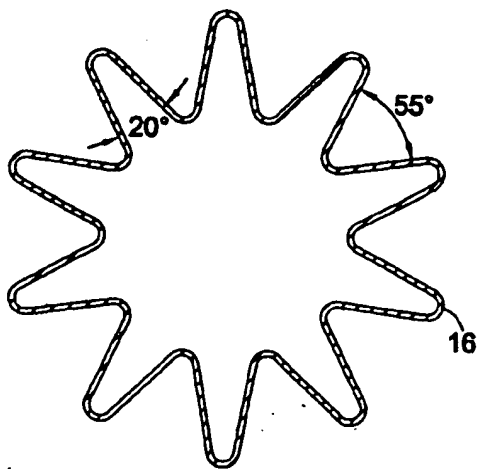
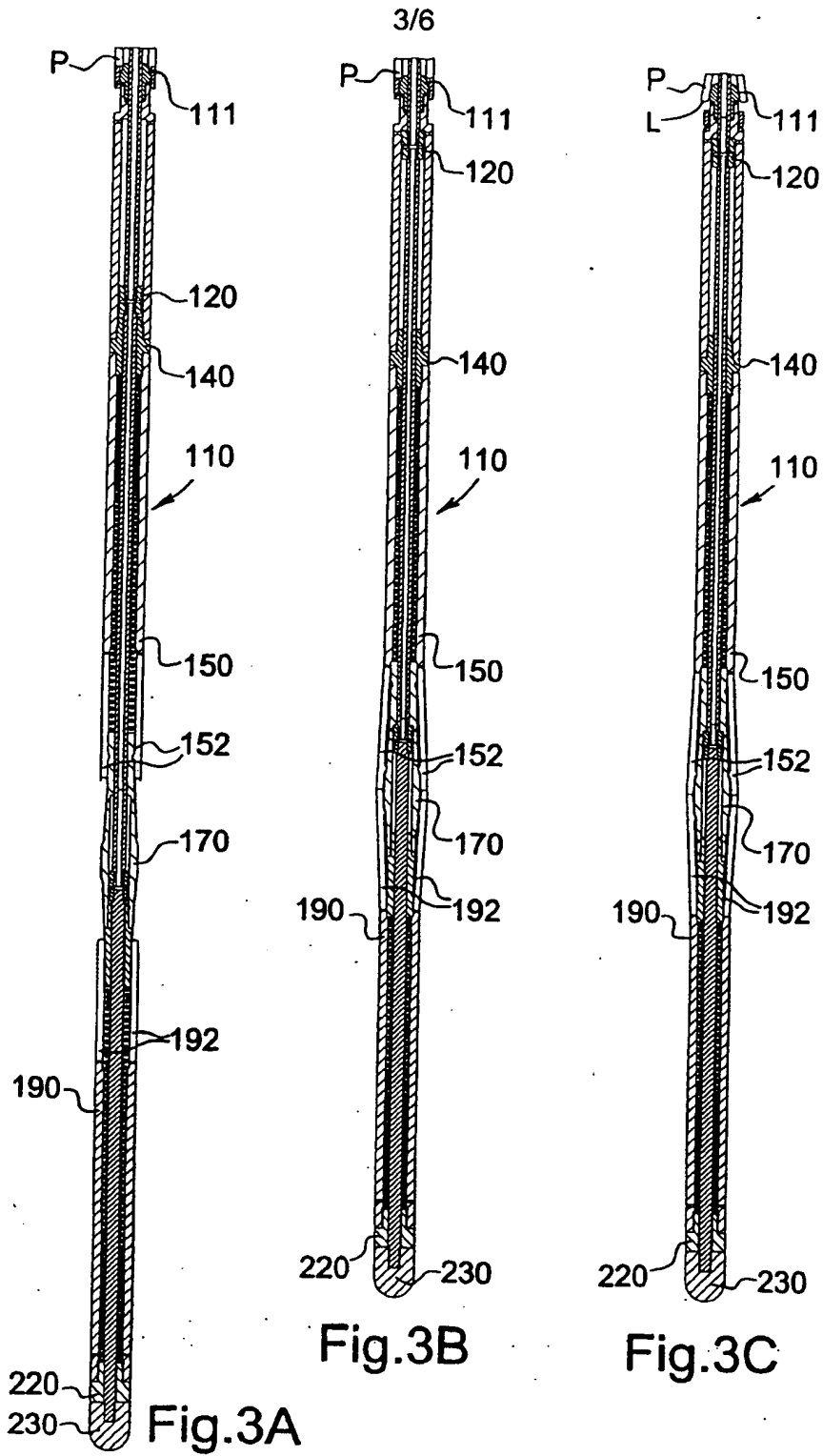
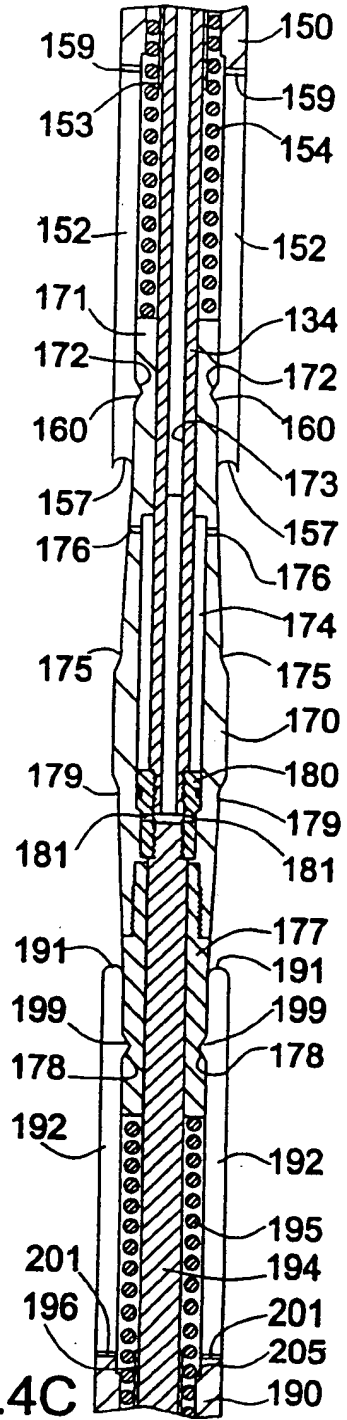
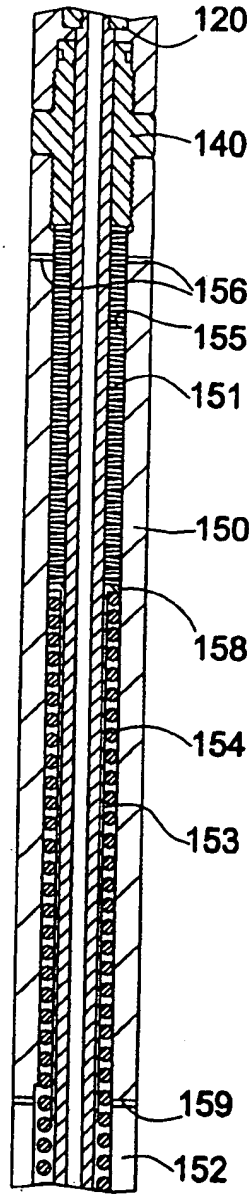
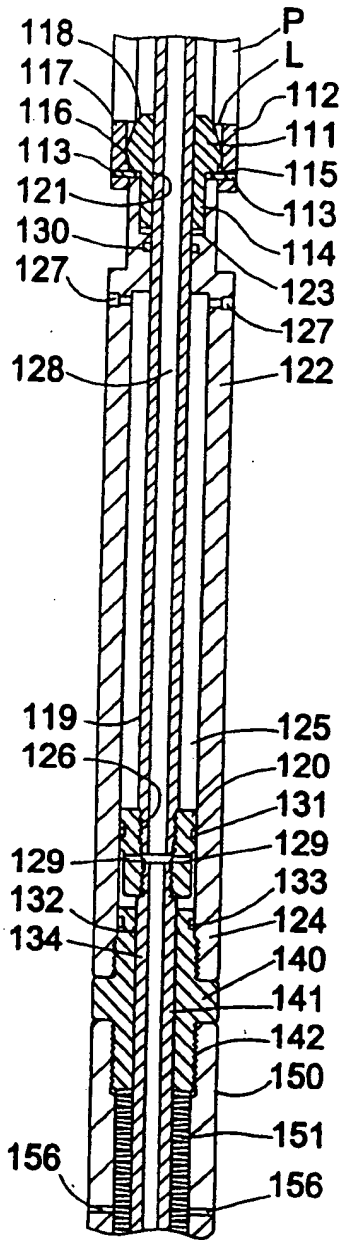

Fig.2C





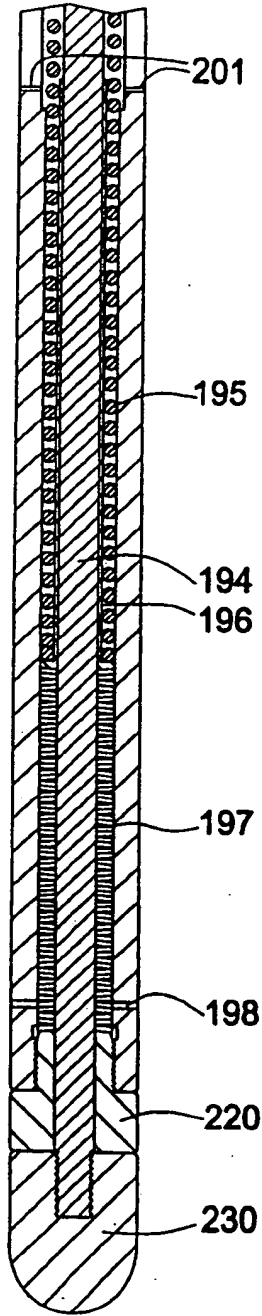

Fig.4D

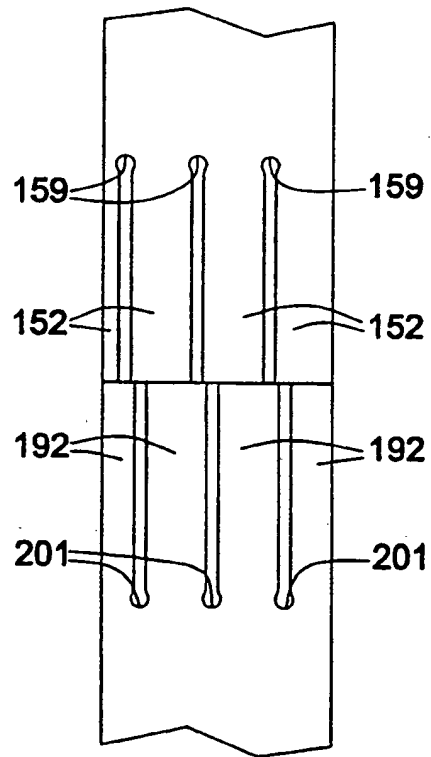
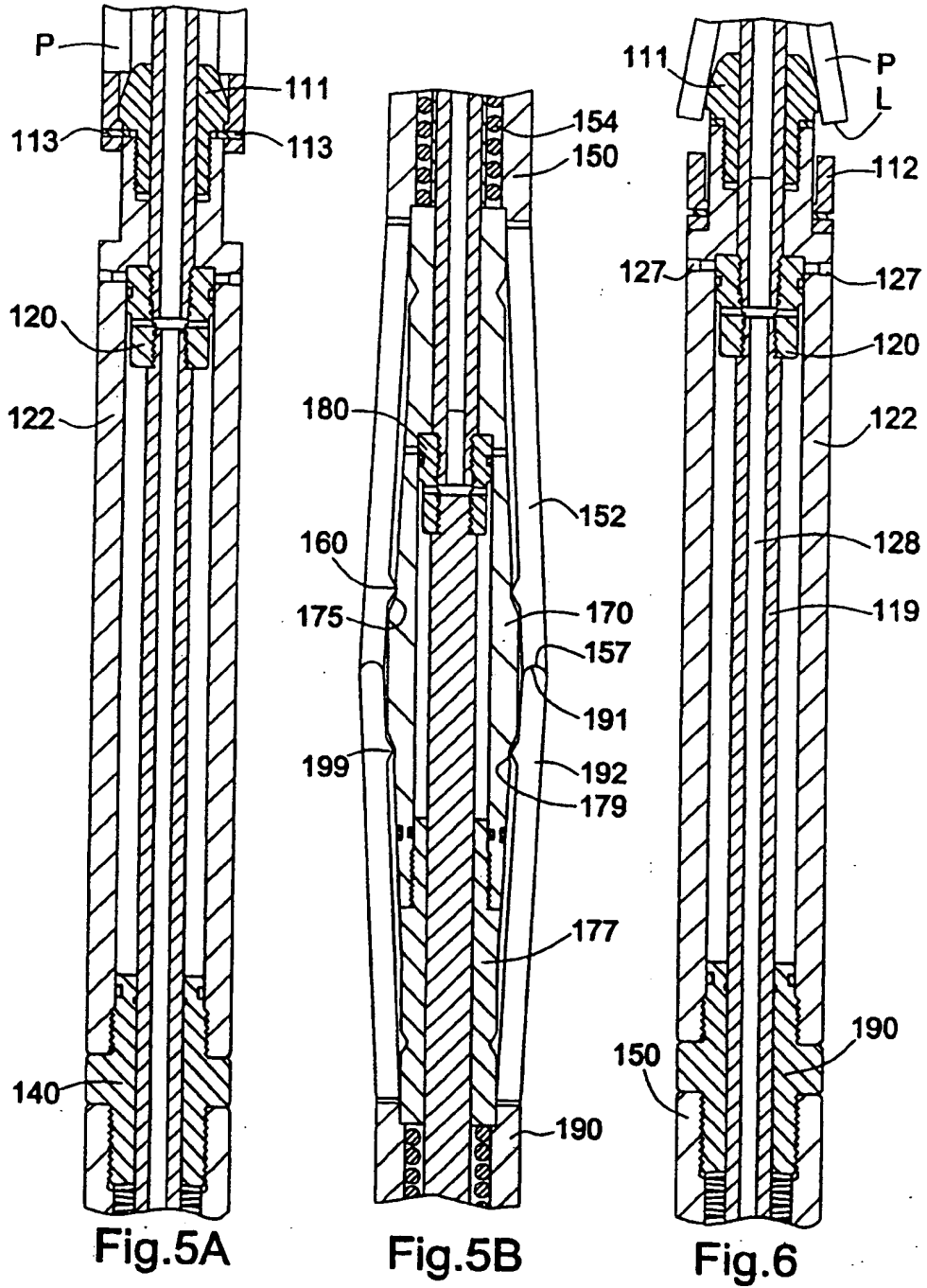

Fig.4E



INTERNATIONAL SEARCH REPORT

International Application No
PCT/GB 99/03585

A. CLASSIFICATION OF SUBJECT MATTER IPC 7 E21B29/10 E21B43/10 E21B17/02 E21B17/08				
According to International Patent Classification (IPC) or to both national classification and IPC				
B. FIELDS SEARCHED Minimum documentation searched (classification system followed by classification symbols) IPC 7 E21B				
Documentation searched other than minimum documentation to the extent that such documents are included in the fields searched				
Electronic data base consulted during the international search (name of data base and, where practical, search terms used)				
C. DOCUMENTS CONSIDERED TO BE RELEVANT				
Category	Citation of document, with indication, where appropriate, of the relevant passages	Relevant to claim No.		
X	WO 98 22690 A (SHELL CANADA LTD ;SHELL INT RESEARCH (NL)) 28 May 1998 (1998-05-28) page 3, line 26 -page 4, line 7 page 2, line 12,13 figure 2	1,15		
Y	---	5,6,9		
Y	WO 98 21444 A (LUCAS BRIAN RONALD ;WEATHERFORD LAMB (US)) 22 May 1998 (1998-05-22) claims 29,30	5,6,9		
X	WO 98 42947 A (PETROLINE WELLSYSTEMS LTD ;METCALFE PAUL D (GB)) 1 October 1998 (1998-10-01) page 10, line 21-25 page 11, line 12-20 figures 2,4	1,15		
--- -/--				
<input checked="" type="checkbox"/> Further documents are listed in the continuation of box C.				
<input checked="" type="checkbox"/> Patent family members are listed in annex.				
* Special categories of cited documents :				
<table style="width: 100%; border: none;"> <tr> <td style="width: 50%; border: none; vertical-align: top;"> *A* document defining the general state of the art which is not considered to be of particular relevance *E* earlier document but published on or after the international filing date *L* document which may throw doubts on priority claim(s) or which is cited to establish the publication date of another citation or other special reason (as specified) *O* document referring to an oral disclosure, use, exhibition or other means *P* document published prior to the international filing date but later than the priority date claimed </td> <td style="width: 50%; border: none; vertical-align: top;"> *T* later document published after the international filing date or priority date and not in conflict with the application but cited to understand the principle or theory underlying the invention *X* document of particular relevance; the claimed invention cannot be considered novel or cannot be considered to involve an inventive step when the document is taken alone *Y* document of particular relevance; the claimed invention cannot be considered to involve an inventive step when the document is combined with one or more other such documents, such combination being obvious to a person skilled in the art. *B* document member of the same patent family </td> </tr> </table>			*A* document defining the general state of the art which is not considered to be of particular relevance *E* earlier document but published on or after the international filing date *L* document which may throw doubts on priority claim(s) or which is cited to establish the publication date of another citation or other special reason (as specified) *O* document referring to an oral disclosure, use, exhibition or other means *P* document published prior to the international filing date but later than the priority date claimed	*T* later document published after the international filing date or priority date and not in conflict with the application but cited to understand the principle or theory underlying the invention *X* document of particular relevance; the claimed invention cannot be considered novel or cannot be considered to involve an inventive step when the document is taken alone *Y* document of particular relevance; the claimed invention cannot be considered to involve an inventive step when the document is combined with one or more other such documents, such combination being obvious to a person skilled in the art. *B* document member of the same patent family
A document defining the general state of the art which is not considered to be of particular relevance *E* earlier document but published on or after the international filing date *L* document which may throw doubts on priority claim(s) or which is cited to establish the publication date of another citation or other special reason (as specified) *O* document referring to an oral disclosure, use, exhibition or other means *P* document published prior to the international filing date but later than the priority date claimed	*T* later document published after the international filing date or priority date and not in conflict with the application but cited to understand the principle or theory underlying the invention *X* document of particular relevance; the claimed invention cannot be considered novel or cannot be considered to involve an inventive step when the document is taken alone *Y* document of particular relevance; the claimed invention cannot be considered to involve an inventive step when the document is combined with one or more other such documents, such combination being obvious to a person skilled in the art. *B* document member of the same patent family			
Date of the actual completion of the international search <p style="text-align: center; font-weight: bold;">7 January 2000</p>	Date of mailing of the international search report <p style="text-align: center; font-weight: bold;">17/01/2000</p>			
Name and mailing address of the ISA European Patent Office, P.B. 5918 Patentlaan 2 NL - 2280 HV Rijswijk Tel. (+31-70) 340-2040, Tx. 31 651 epo nl, Fax: (+31-70) 340-3016	Authorized officer <p style="text-align: center; font-weight: bold;">Schouten, A</p>			

INTERNATIONAL SEARCH REPORT

International Application No
PCT/GB 99/03585

C.(Continuation) DOCUMENTS CONSIDERED TO BE RELEVANT		
Category	Citation of document, with indication, where appropriate, of the relevant passages	Relevant to claim No.
A	WO 97 21901 A (CAMPBELL ALASDAIR ;METCALFE PAUL DAVID (GB); PETROLINE WIRELINE SE) 19 June 1997 (1997-06-19) the whole document	1,5,6,8, 9,15
A	WO 96 37681 A (CAMPBELL ALASDAIR ;PETROLINE WIRELINE SERVICES (GB)) 28 November 1996 (1996-11-28) the whole document	1,5,6,8, 9,15

1

INTERNATIONAL SEARCH REPORT

Information on patent family members

Inter. nal Application No
PCT/GB 99/03585

Patent document cited in search report	A	Publication date	Patent family member(s)	Publication date
WO 9822690	A	28-05-1998	AU 5656598	10-06-1998
			EP 0939854	08-09-1999
			NO 992359	14-05-1999
WO 9821444	A	22-05-1998	US 5785120	28-07-1998
			US 5957195	28-09-1999
			AU 4955097	03-06-1998
			EP 0948703	13-10-1999
			NO 991666	23-06-1999
WO 9842947	A	01-10-1998	AU 6739298	20-10-1998
			EP 0968351	05-01-2000
			NO 994591	16-11-1999
WO 9721901	A	19-06-1997	AU 1068897	03-07-1997
			EP 0865562	23-09-1998
			GB 2327994	10-02-1999
			NO 982625	10-08-1998
WO 9637681	A	28-11-1996	AU 698614	05-11-1998
			AU 5826596	11-12-1996
			AU 7349396	11-12-1996
			CA 2221789	28-11-1996
			CN 1185190	17-06-1998
			DE 69603725	16-09-1999
			WO 9637680	28-11-1996
			EP 0828918	18-03-1998
			EP 0824628	25-02-1998
			JP 11505902	25-05-1999
			JP 11505904	25-05-1999
			NO 975348	23-01-1998
			NO 975350	16-01-1998
			NZ 308590	27-04-1998
NZ 309768	30-08-1999			
US 5984568	16-11-1999			
US 5924745	20-07-1999			